

ELECTRON TUBE DATA SHEET
WESTERN ELECTRIC 437A ELECTRON TUBE

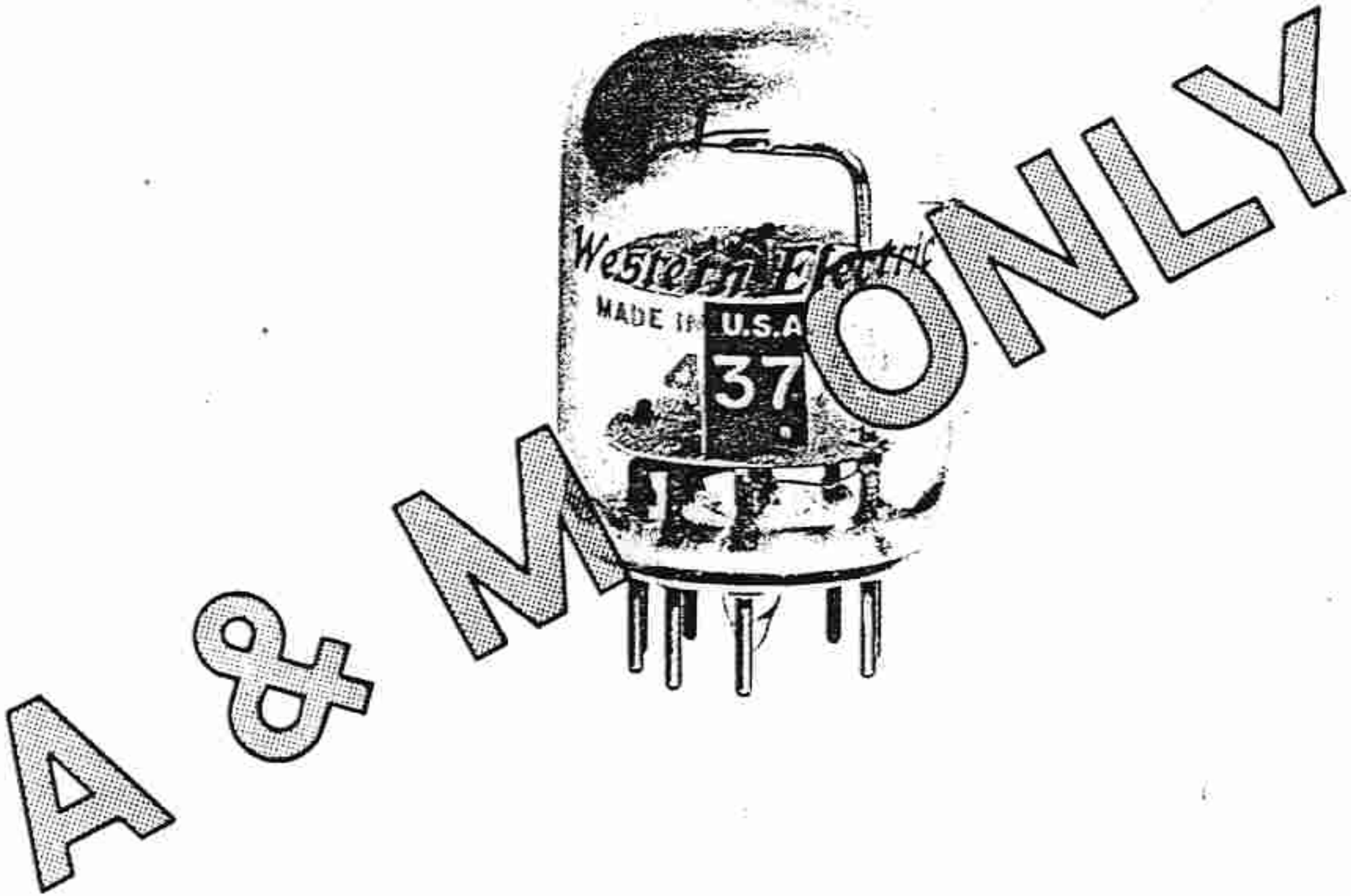

DESCRIPTION

The 437A electron tube is a high figure of merit triode with an indirectly heated cathode. It was designed primarily for the output amplifier of the L-3 tandem two stage amplifier.

CHARACTERISTICS

Heater Voltage	6.3 volts
Cathode Current	36.5 milliamperes
Transconductance	46000 micromhos

($E_p = 160$ volts; $E_{ccl} = +7.5$ volts; $R_k = 262$ ohms)

GENERAL CHARACTERISTICSELECTRICAL DATA

Heater Voltage		6.3 volts
Heater Current		450 milliamperes
Direct Interelectrode Capacitances	Without External Shield	With External Shield (RETMA #309)
Grid to Plate (maximum)	3.8	3.8 uuf
Input: g to (h+k+i.s.)	11.1	11.3 uuf
Output: p to (h+k+i.s.)	1.0	2.1 uuf

MECHANICAL DATA

Cathode	Coated Unipotential
Bulb	T9
Base	See outline drawing page 4
Mounting Position	Any
Dimensions and pin connections shown in outline drawing on page 4	

MAXIMUM RATINGS, Design Center Values

Plate Voltage	250 volts
Plate Dissipation	7.0 watts
Control Grid Dissipation	see footnote 1
Cathode Current	45 milliamperes
Heater-Cathode Voltage	50 volts
Bulb Temperature	130 centigrade

MAXIMUM CIRCUIT VALUES

Grid Circuit Resistance:	
For Fixed Bias	0.05 megohm
For Cathode Bias	0.10 megohm

TYPICAL OPERATING CONDITIONS AND CHARACTERISTICS

Plate Voltage	140	180	160	volts
Control Grid Voltage	-2.0	-3.0	---	volts
Control Grid Supply Voltage ²	---	---	+7.5	volts
Cathode Bias Resistor ²	---	---	262	ohms
Plate Current	29.0	25.0	36.5	milliamperes
Amplification Factor	41.0	41.0	41.0	
Plate Resistance	950	980	900	ohms
Transconductance	43000	42000	46000	micromhos
Control Grid Voltage (approximate) for Plate Current of 10 microamperes	-5.0	-6.3	---	volts
Modulation				
Second Order (2F) ³	--	---	-37	db
Third Order (3F) ⁴	---	---	-56	db
Load Resistance	---	---	270	ohms

Note 1: Operation with the control grid positive with respect to cathode is not recommended.

Note 2: Reference point for Control Grid Voltage is the negative end of the cathode bias resistor.

Note 3: Ratio of product to fundamental at output for 0.1 volt rms signal from grid to cathode.

Note 4: Ratio of product to fundamental at output for a 0.2 volt rms signal from grid to cathode.

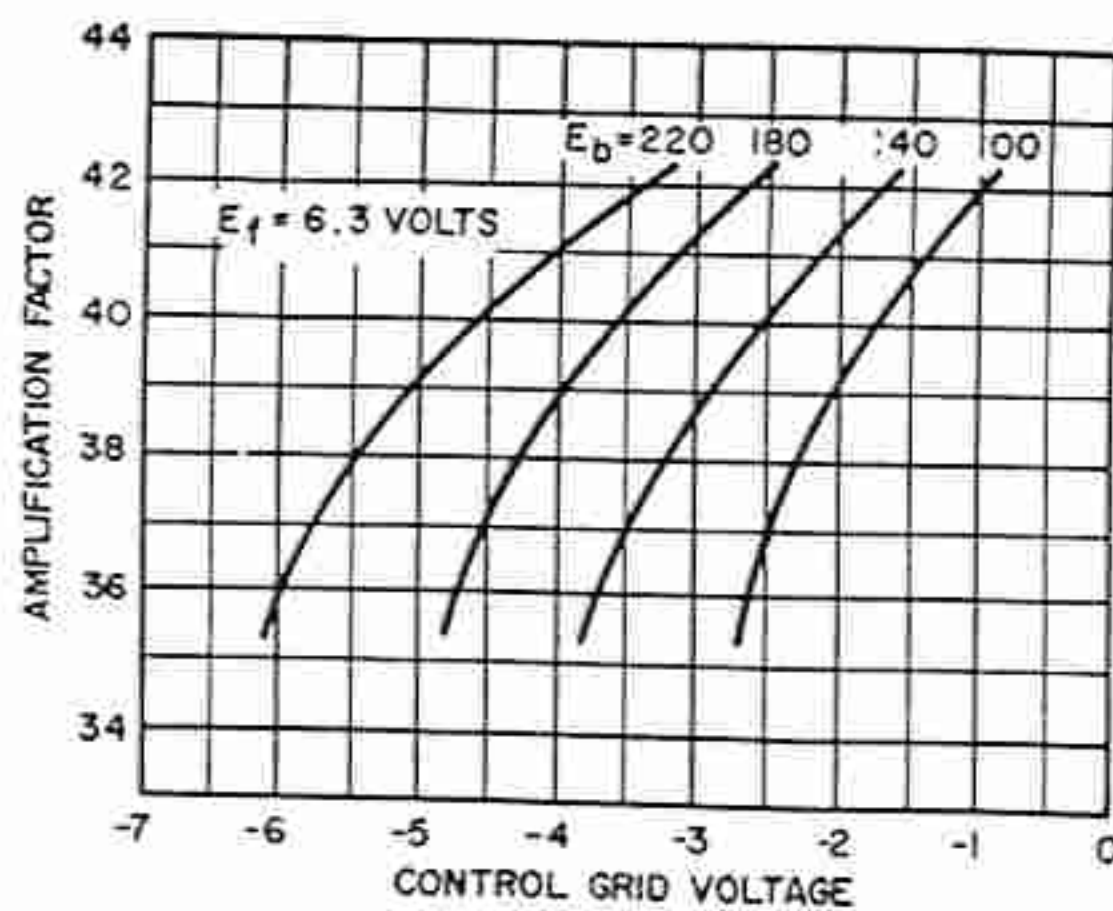
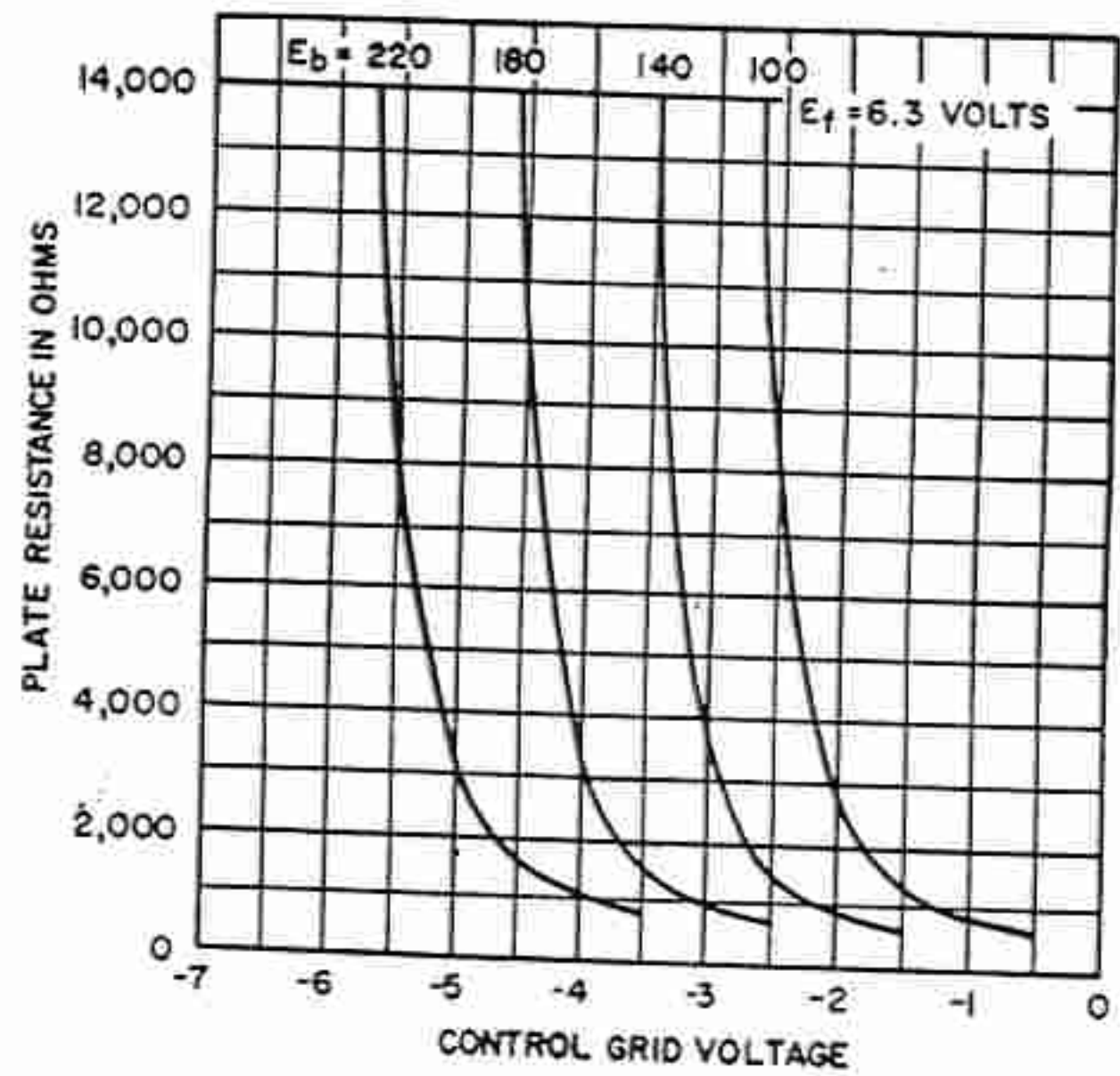
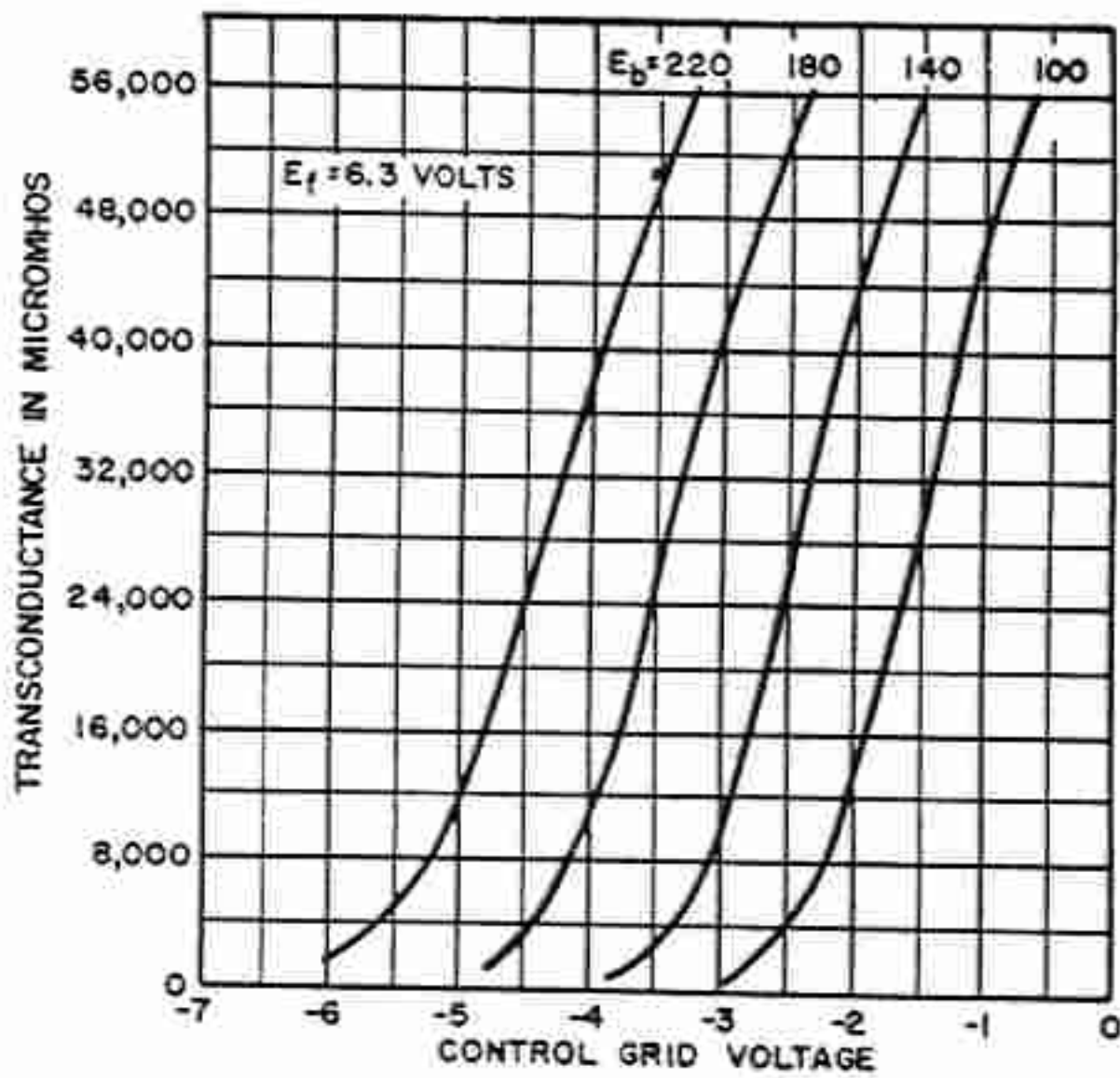
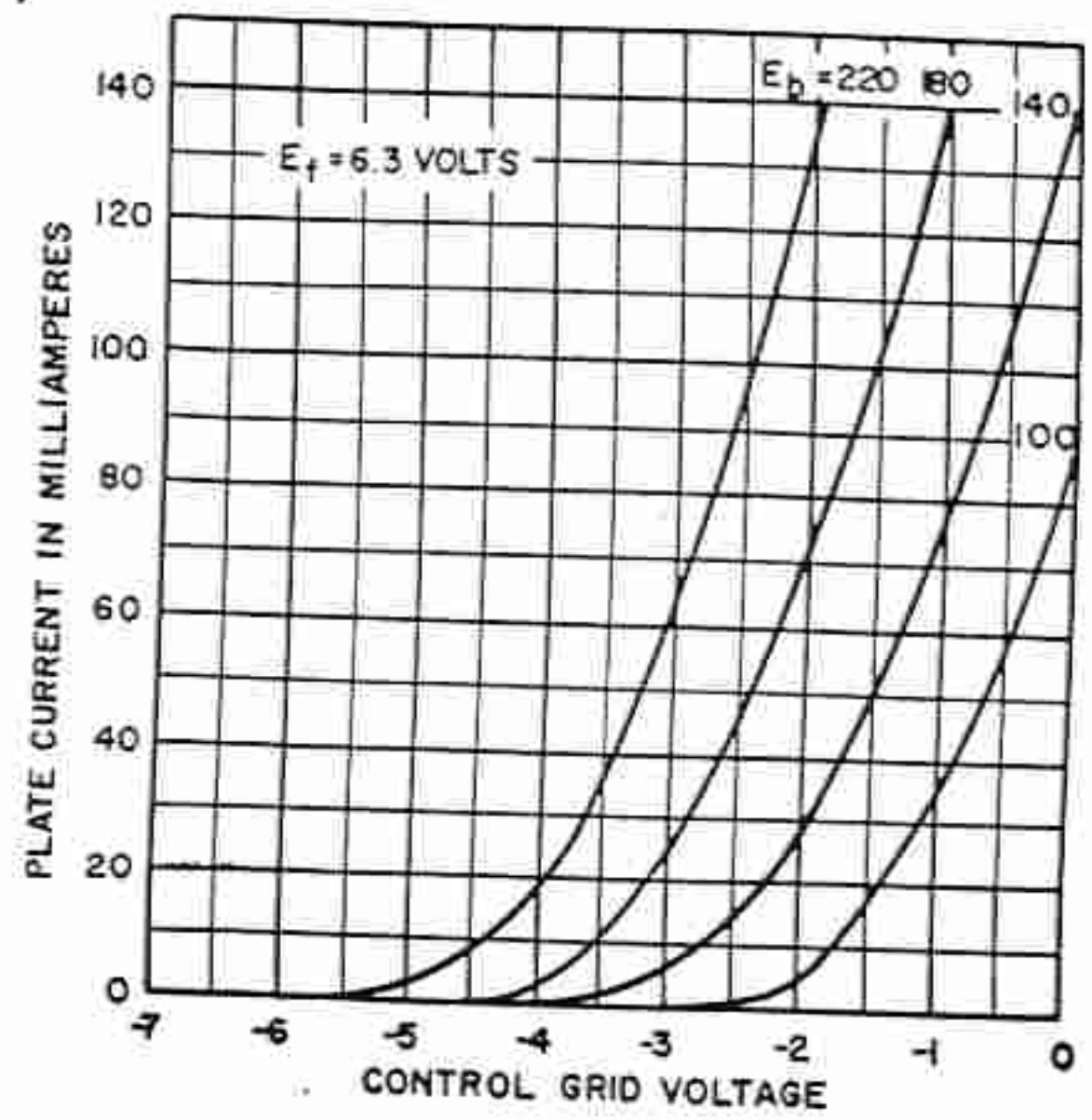
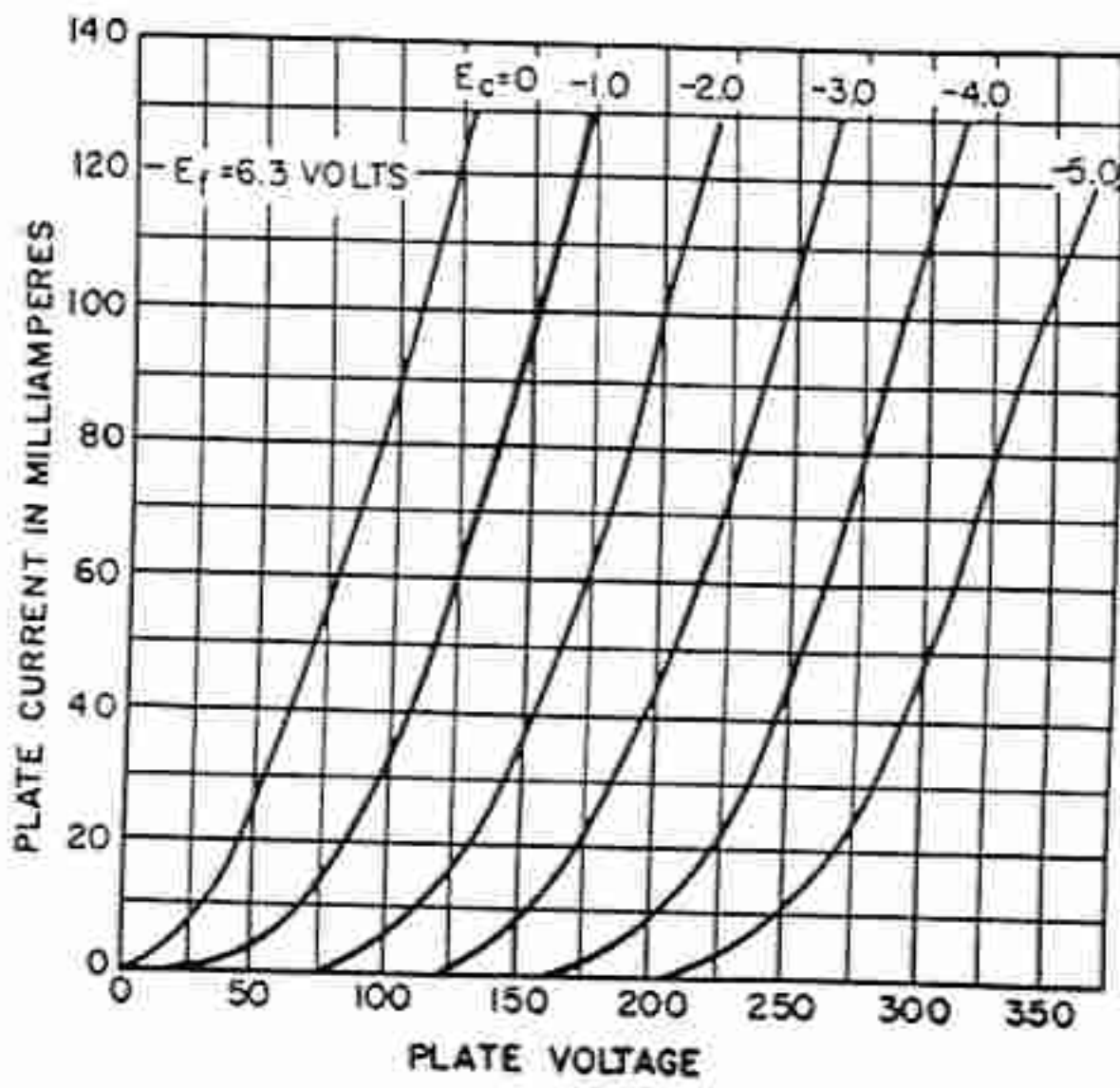

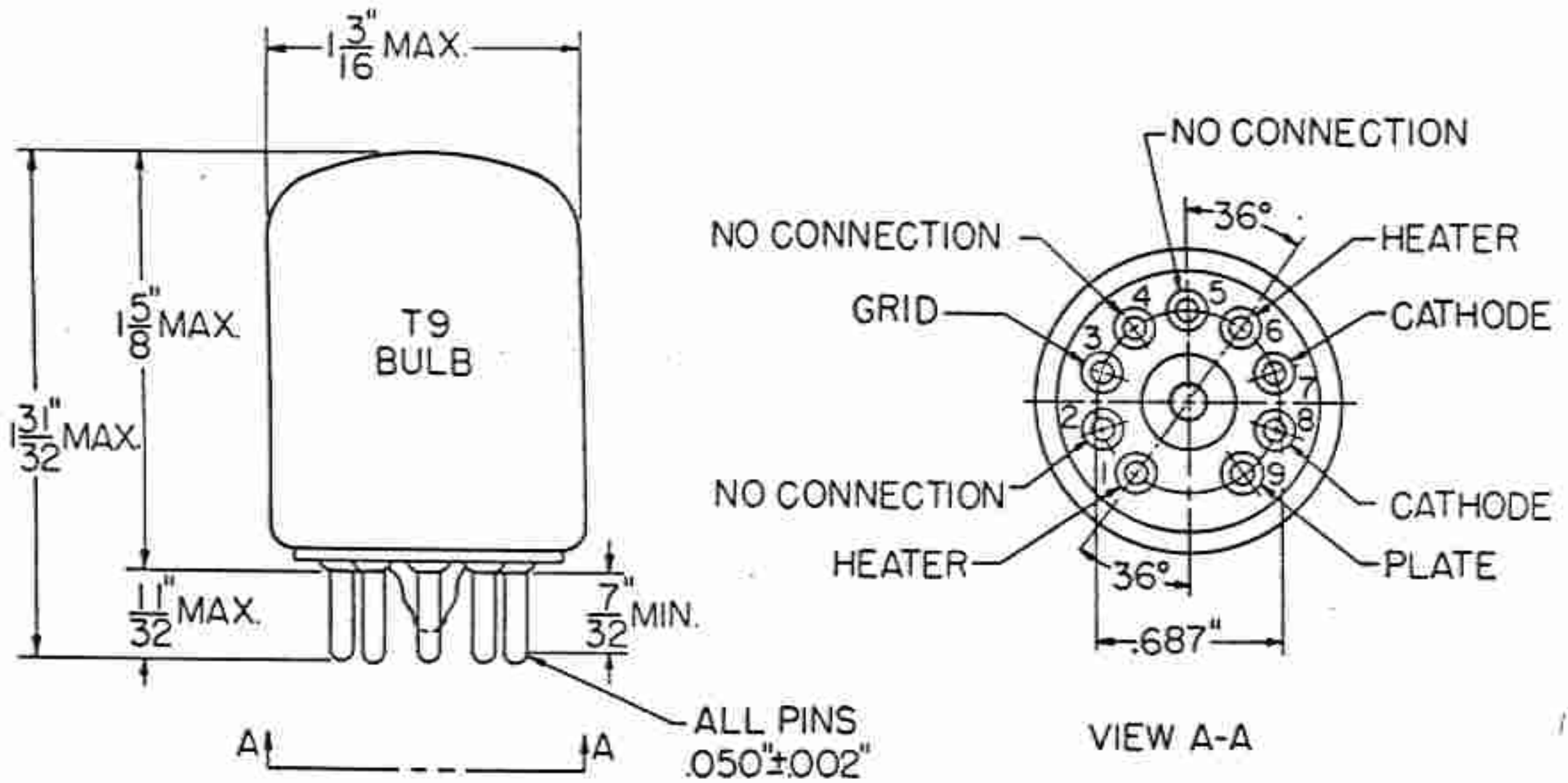

A development of Bell Telephone Laboratories, the research laboratories of the American Telephone and Telegraph Company and the Western Electric Company